

LVA series of 4-quadrant amplifiers

**AUTOMOTIVE SUPPLY SIMULATION
AT IT'S BEST**



LVA 1000 Front panel

- ✓ Extremely low harmonic distortion - even under very non-linear load conditions
- ✓ Very fast slew rate > 20V/μs
- ✓ Operates from DC up to 50kHz large signal bandwidth (-3dB)
- ✓ Small signal bandwidth up to 300kHz
- ✓ High short-term overload characteristic (for 30s)
- ✓ Very high peak-load ability (up to 200ms)
- ✓ Programmable internal resistance 0 ... 200 mΩ
- ✓ Sink operation mode included – real 4-quadrant operation mode to be disabled through the touch panel menu
- ✓ Unsymmetric or symmetric voltage ranges
- ✓ Touch panel operation 7" 800x480

The relating standards:

ISO 7637-2
 ISO 16750-2
 ISO 21848
 LV 124
 VDA 320 (LV 148)
 SAE J 1113-11
 BMW GS 95002
 BMW GS 95003-2
 BMW GS 95024-2-2
 BMW GS 95026
 Ford FMC 1278
 General Motors GMW 3097
 JLR-EMC-CSv1.04A
 Mercedes-Benz LV 124-1
 Mercedes-Benz LV 148
 Mitsubishi ES-X82115
 Nissan 28400NDS02_3
 PSA B21 7110
 Renault 36-00-808/--M
 VW 80000
 VW 82148
 VW TL 81000

**THE REFERENCE SOURCE FOR AUTOMOTIVE APPLICATIONS
PERFECT FOR MANY AVIONIC AND MILITARY STANDARDS**

AMPLIFIER RANGES – FRONT PANEL MENUS AND OPTIONS

The LVA Amplifier offers four standard voltage ranges:

- 20V_{DC}
- 36V_{DC}
- 54V_{DC}
- 70V_{DC}

Depending on the amplifier's output stage structure, the voltage ranges can be symmetric or asymmetric.

The built in oscillator unit supplies several standard functions:

- DC signal, Sine wave
- Rectangular wave
- Triangular wave
- Ramp (amplitude sweep)
- User defined

Alternatively, an external signal generator can be used.

For each voltage range the operating mode options can be selected.

With the option "OPD" (over-voltage protection device) the EUT's supply voltage is monitored and the EUT is protected against very fast rising high voltage.

The LVA allows optionally specifying the amplifier's internal resistance from 0 to 200mΩ in each mode of operation.

Optionally the sink mode capability can be disabled. A built-in measurement unit displays the relevant measurement values.

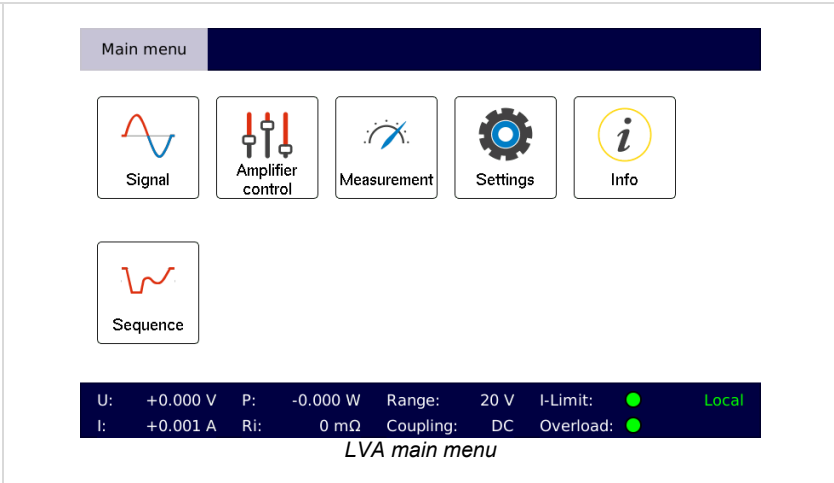

The screenshot shows the 'Main menu' with five icons: Signal, Amplifier control, Measurement, Settings, and Info. Below the icons is a 'Sequence' icon. At the bottom, a status bar displays the following data:

U:	+0.000 V	P:	-0.000 W	Range:	20 V	I-Limit:	●	Local
I:	+0.001 A	Ri:	0 mΩ	Coupling:	DC	Overload:	●	

LVA main menu

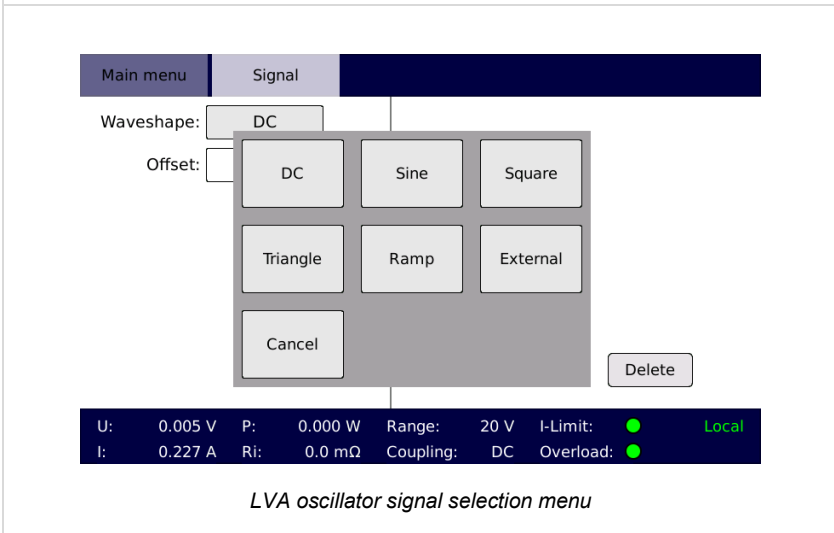

The screenshot shows the 'Signal' menu with a 'Waveshape:' dropdown set to 'DC' and an 'Offset:' field. A grid of buttons is displayed for selection:

DC	Sine	Square
Triangle	Ramp	External
Cancel		

A 'Delete' button is located to the right of the grid. At the bottom, a status bar displays the following data:

U:	0.005 V	P:	0.000 W	Range:	20 V	I-Limit:	●	Local
I:	0.227 A	Ri:	0.0 mΩ	Coupling:	DC	Overload:	●	

LVA oscillator signal selection menu

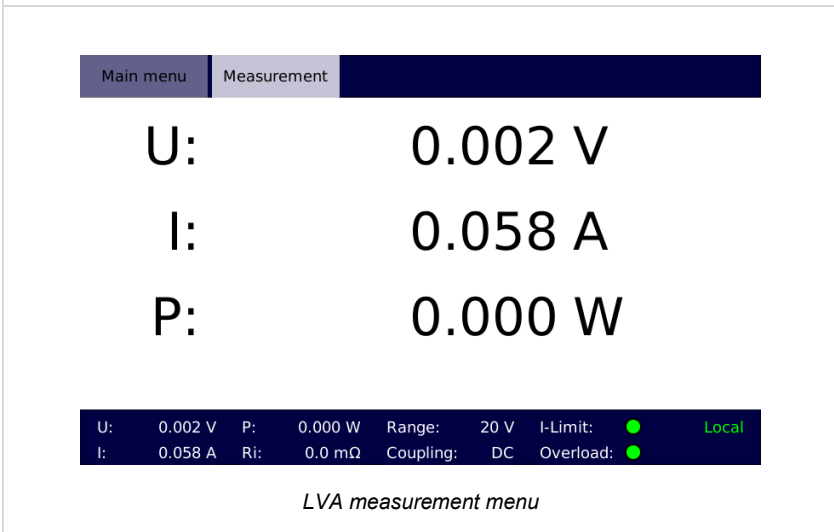

The screenshot shows the 'Measurement' menu with large text displaying the current measurement values:

U: 0.002 V

I: 0.058 A

P: 0.000 W

At the bottom, a status bar displays the following data:

U:	0.002 V	P:	0.000 W	Range:	20 V	I-Limit:	●	Local
I:	0.058 A	Ri:	0.0 mΩ	Coupling:	DC	Overload:	●	

LVA measurement menu

AMPLIFIER CHARACTERISTIC – 4-QUADRANT OPERATION

The LVA amplifier is a real 4-Quadrant Amplifier.

Due to this advanced technology four different application scenarios are possible:

Example values 20V Range:

-U/+I

II. Quadrant

negative voltage, positive current

LVA 2500 example values:

U _{test}	I _{sink cont}	I _{sink short}
-12V	49A _{DC}	99A _{DC}

Typical application:

The LVA simulates a voltage drop of the negative testing voltage and the EUT's input has a capacitive stage feeding energy back into the LVA

+U/+I

I. Quadrant

positive voltage, positive current

LVA 2500 example values:

U _{test}	I _{cont}	I _{short}
12V	105A _{DC}	200A _{DC}

Typical application:

The LVA supplies positive testing voltage to the EUT

III. Quadrant

negative voltage, negative current

LVA 2500 example values:

U _{test}	I _{cont}	I _{short}
-12V	-65A _{DC}	-100A _{DC}

Typical application:

The LVA supplies negative testing voltage to the EUT

IV. Quadrant

positive voltage, negative current

LVA 2500 example values:

U _{test}	I _{sink cont}	I _{sink short}
12V	-65A _{DC}	-100A _{DC}

Typical application:

The LVA simulates a voltage drop and the EUT's input has a capacitive stage feeding energy back into the LVA

-U/-I

+U/-I

UNSYMMETRIC AMPLIFIER CHARACTERISTIC – OUTPUT POWER CAPABILITY
20V Range continuous power P_{cont} : LVA1000 - LVA2500 – LVA5000 – LVA7500

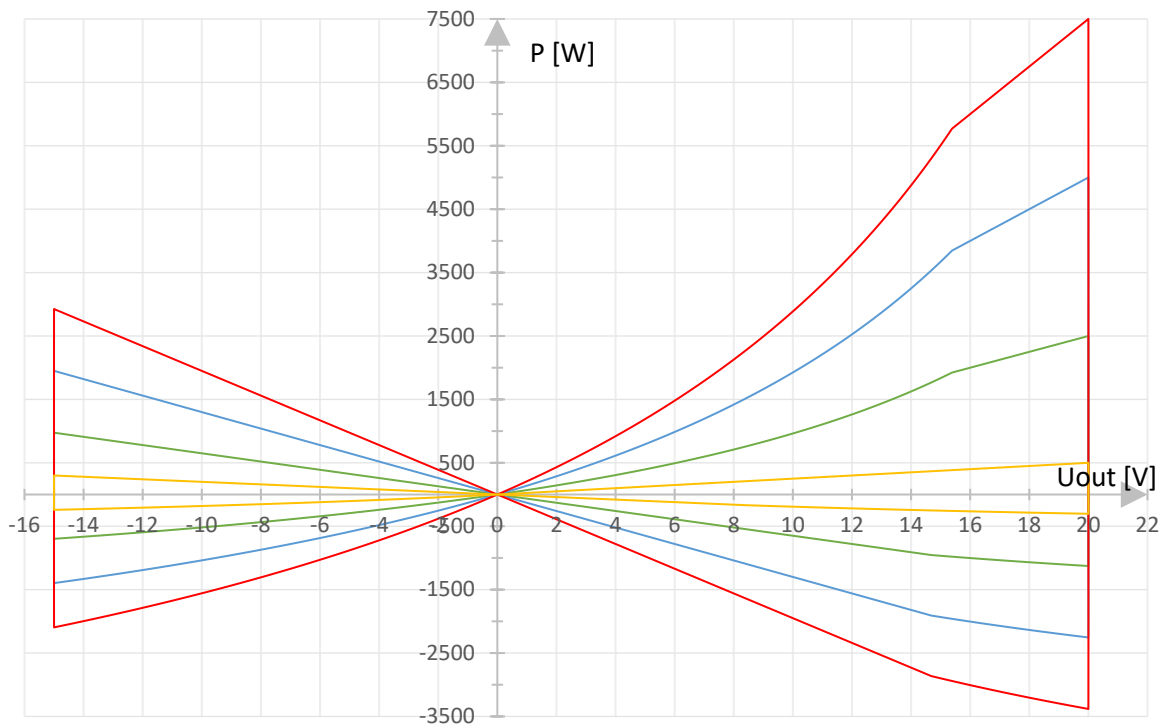

36V Range continuous power P_{cont} : LVA1000 - LVA2500 – LVA5000 – LVA7500

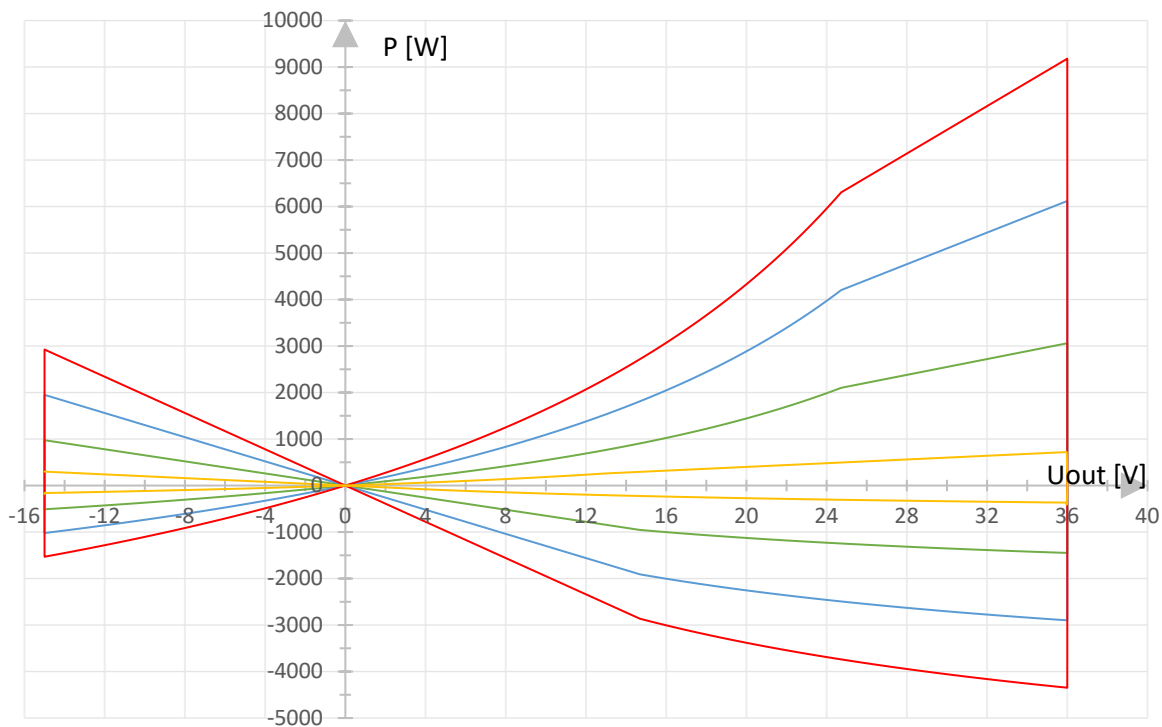

UNSYMMETRIC AMPLIFIER CHARACTERISTIC – OUTPUT POWER CAPABILITY
54V Range continuous power P_{cont} : LVA1000 - LVA2500 – LVA5000 – LVA7500

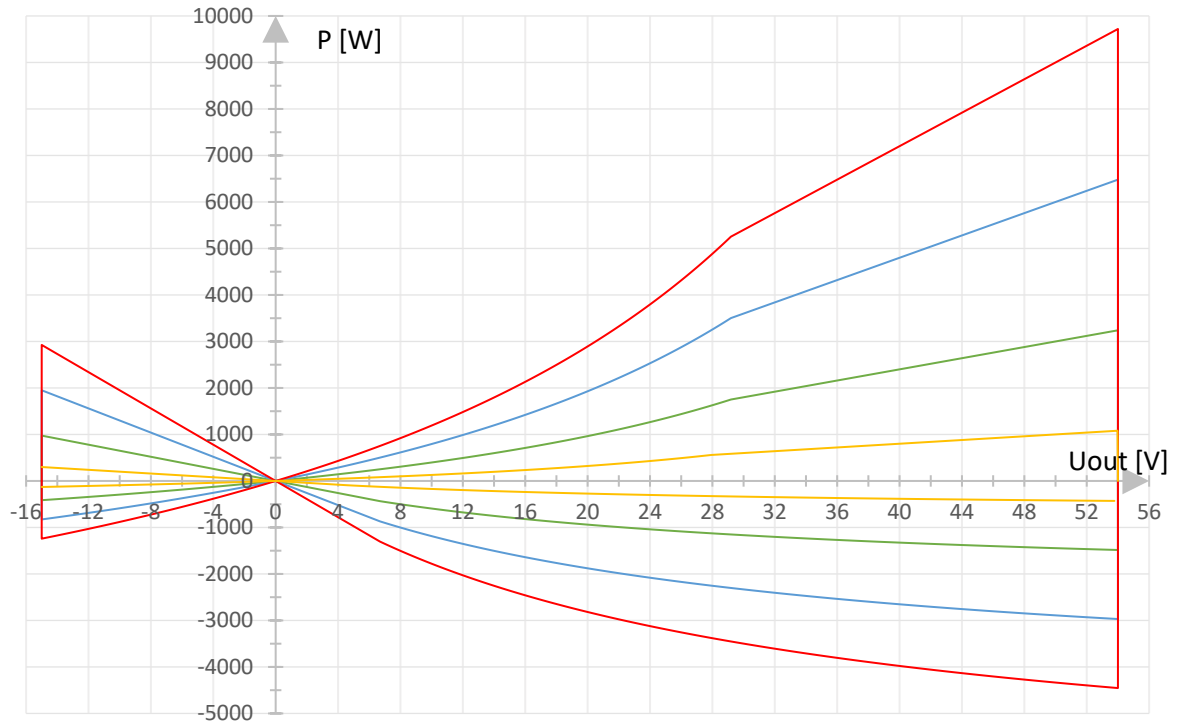

70V Range continuous power P_{cont} : LVA1000 - LVA2500 – LVA5000 – LVA7500

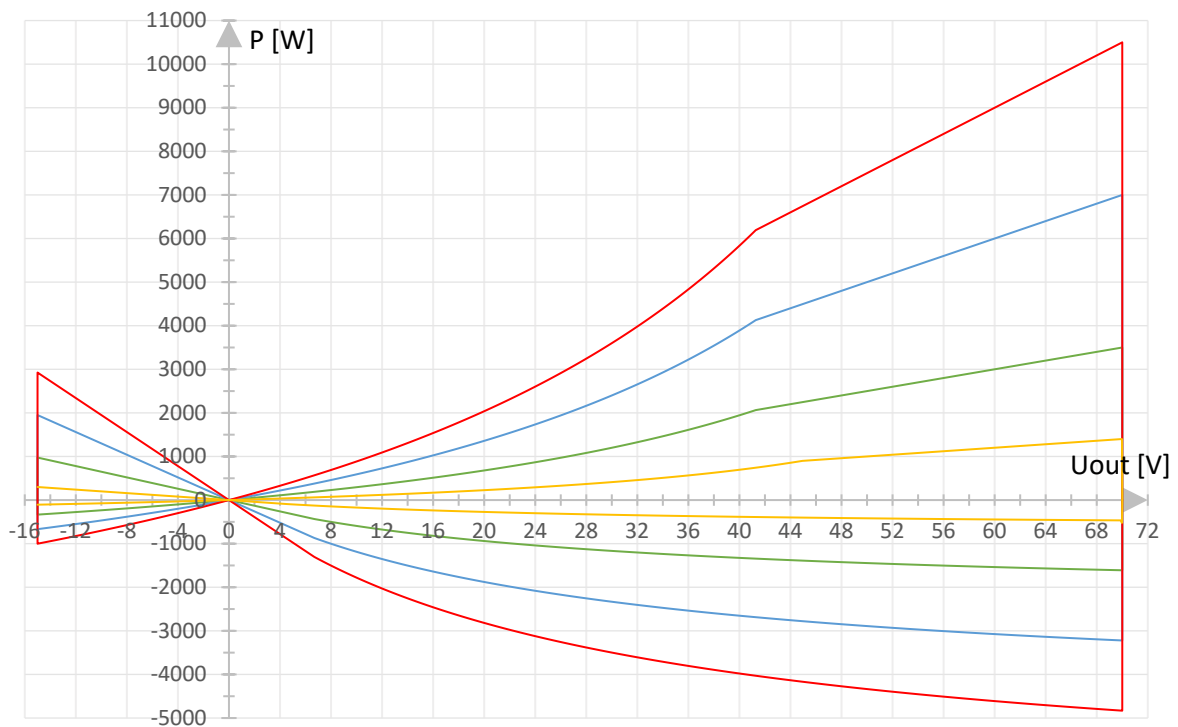

UNSYMMETRIC AMPLIFIER CHARACTERISTIC – OUTPUT CURRENT CAPABILITY
20V Range continuous current I_{cont} : LVA1000 - LVA2500 - LVA5000 - LVA7500

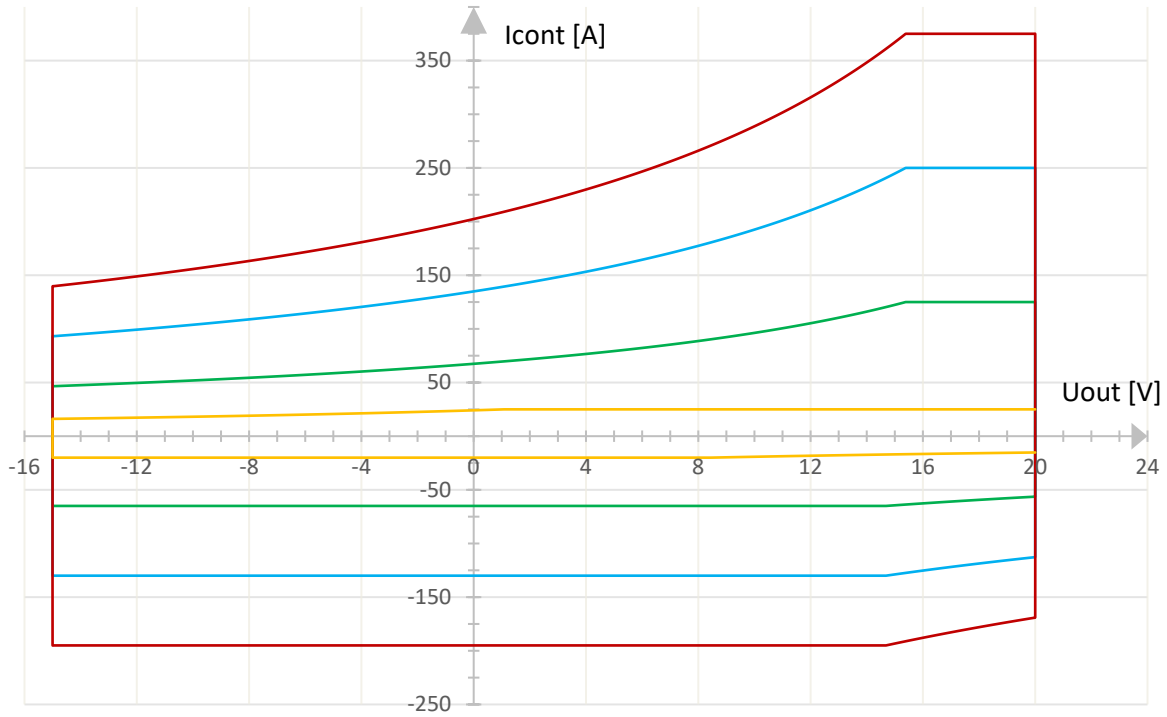

20V Range short-time current I_{short} : LVA1000 - LVA2500 - LVA5000 - LVA7500

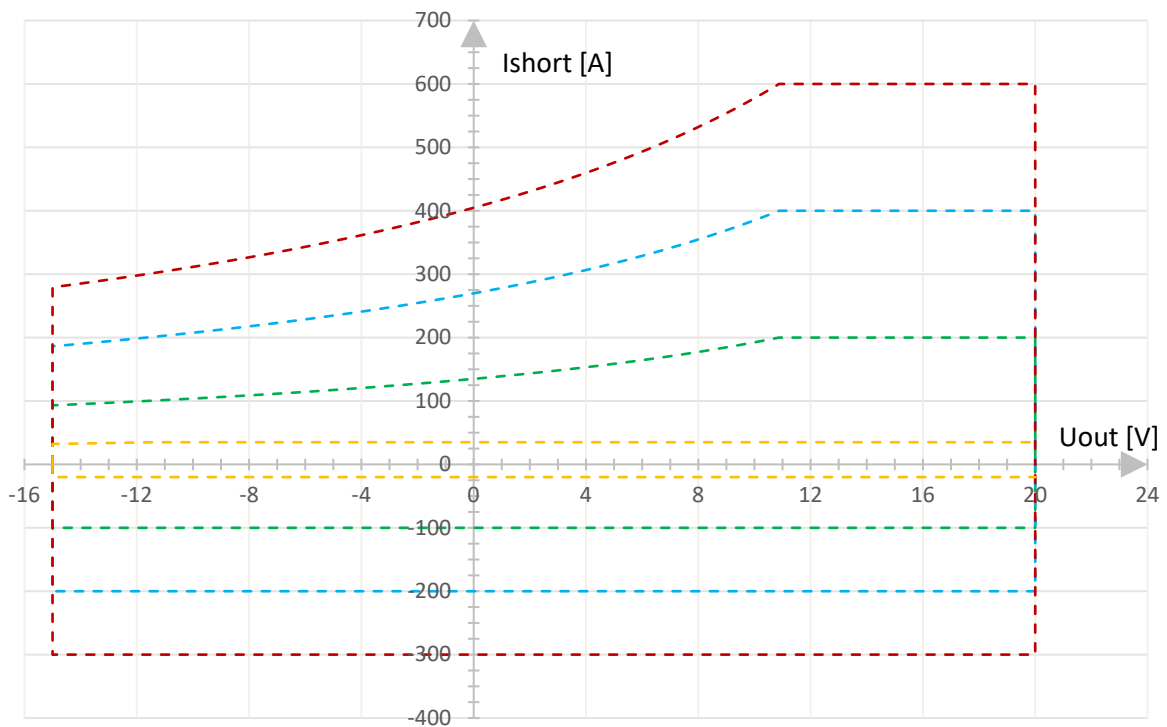

SYMMETRIC AMPLIFIER CHARACTERISTIC – OUTPUT CURRENT CAPABILITY
20V Range continuous current I_{cont} : LVA2500 – LVA5000 – LVA7500

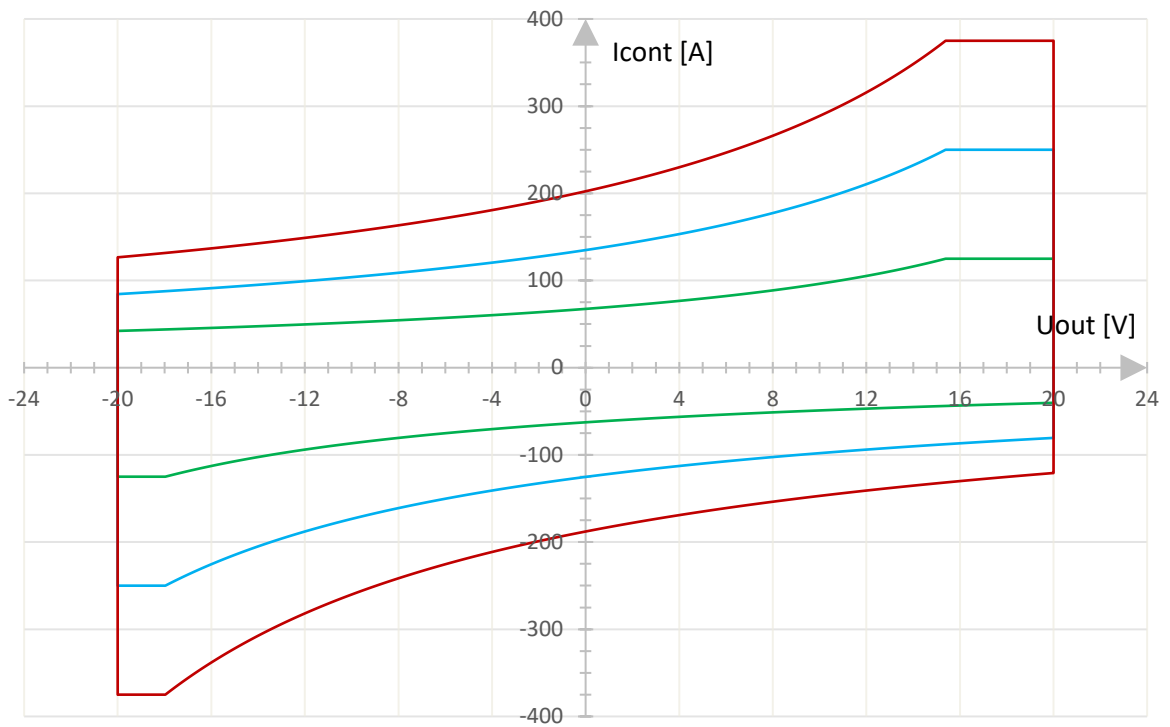

20V Range short-time current I_{short} : LVA2500 – LVA5000 – LVA7500

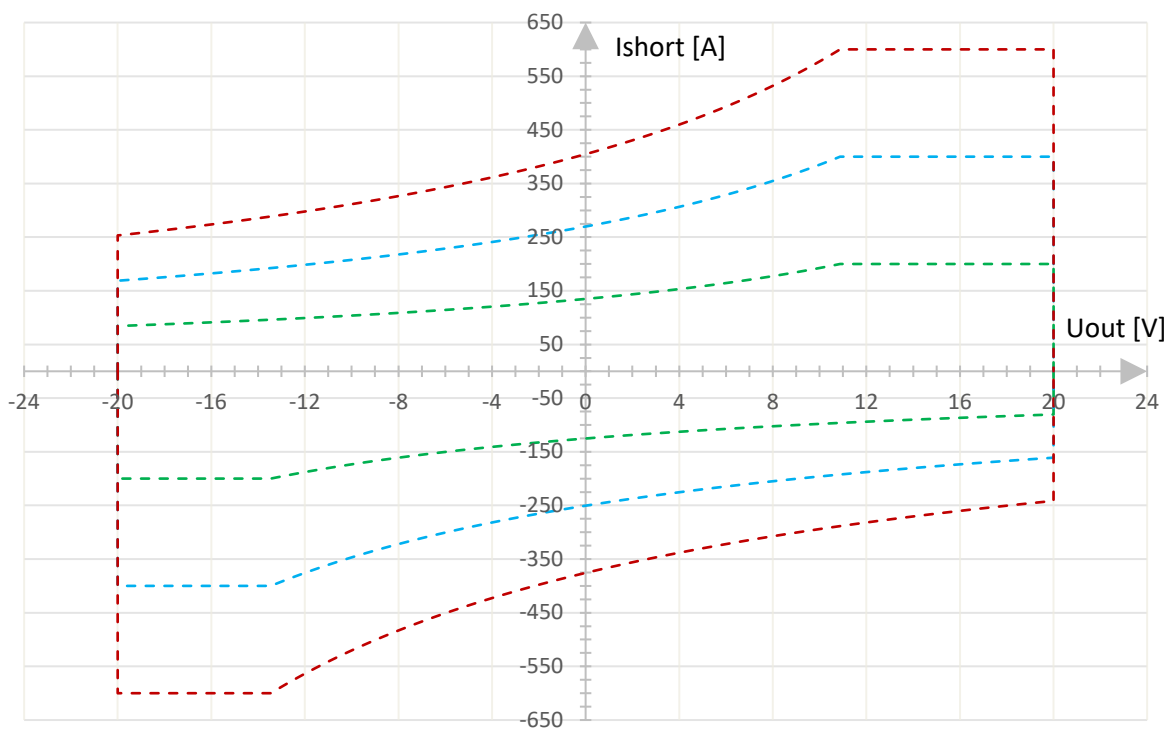

UNSYMMETRIC AMPLIFIER CHARACTERISTIC – OUTPUT CURRENT CAPABILITY
36V Range continuous current I_{cont} : LVA1000 - LVA2500 – LVA5000 – LVA7500

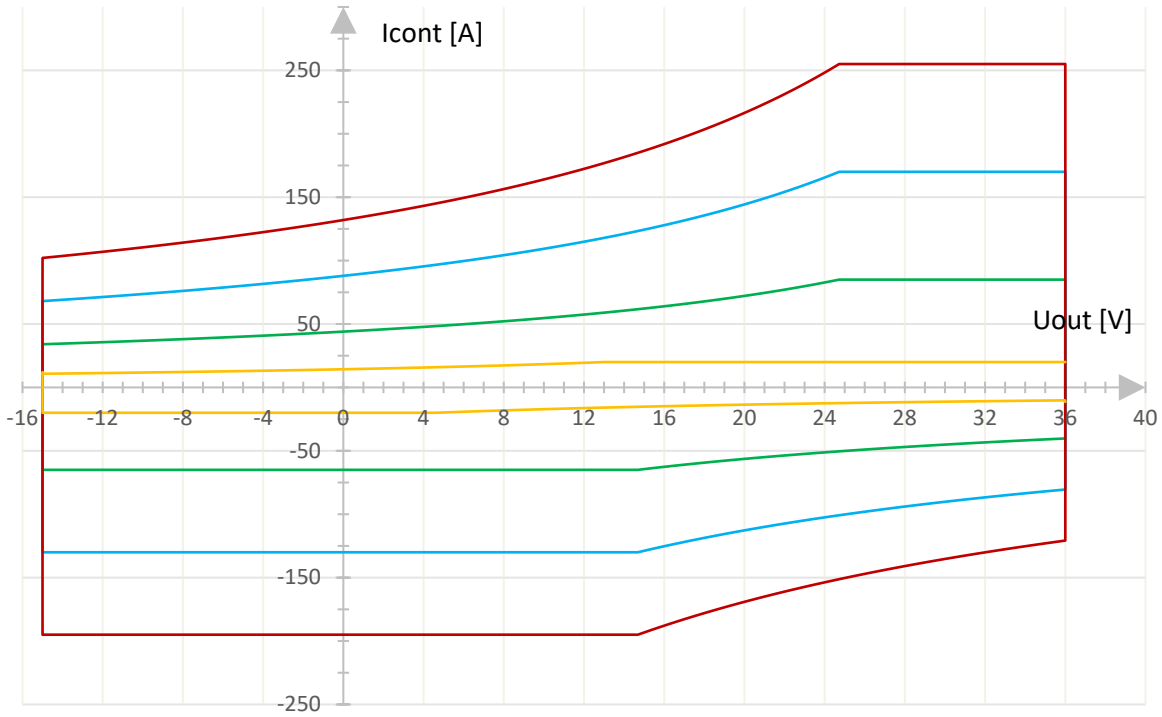

36V Range short-time current I_{short} : LVA1000 - LVA2500 – LVA5000 – LVA7500

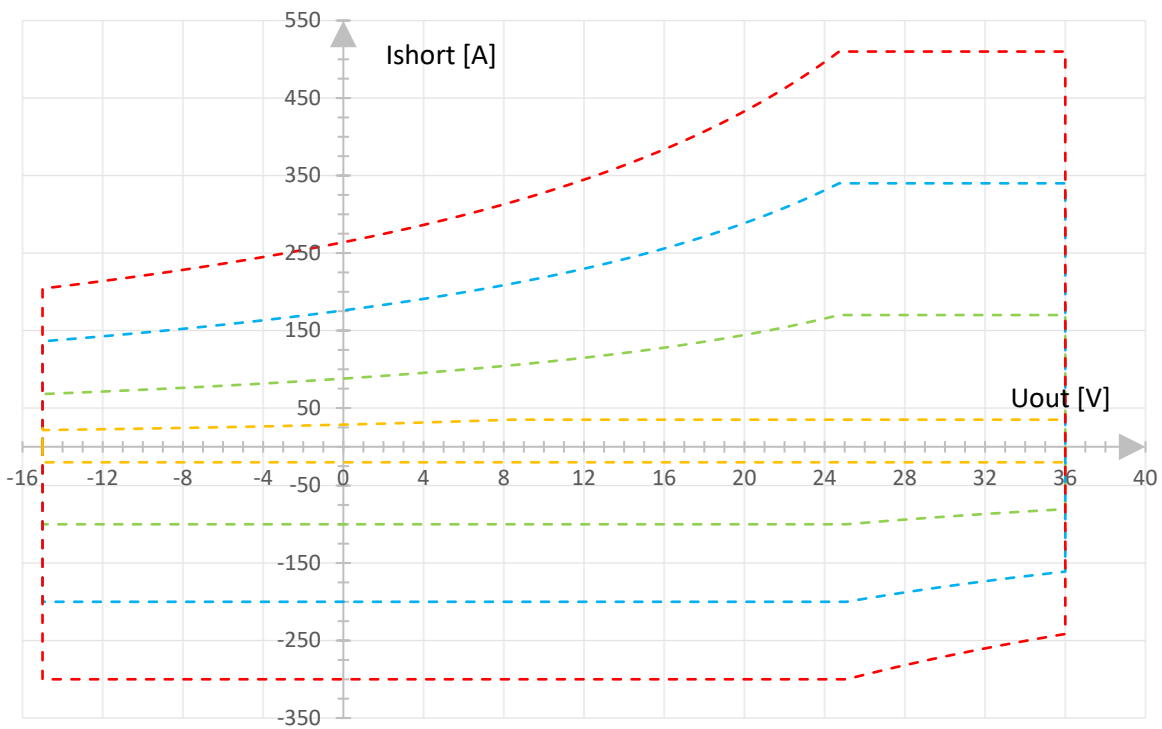

SYMMETRIC AMPLIFIER CHARACTERISTIC – OUTPUT CURRENT CAPABILITY
36V Range continuous current I_{cont} : LVA2500 – LVA5000 – LVA7500

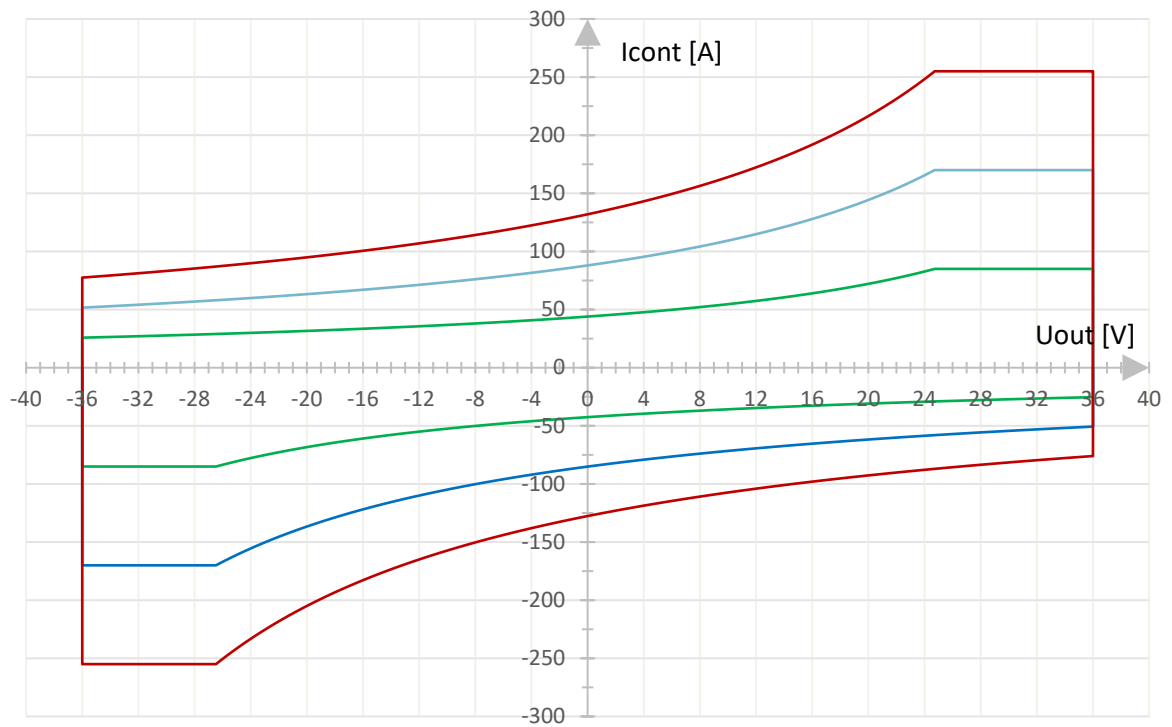

36V Range short-time current I_{short} : LVA2500 – LVA5000 – LVA7500

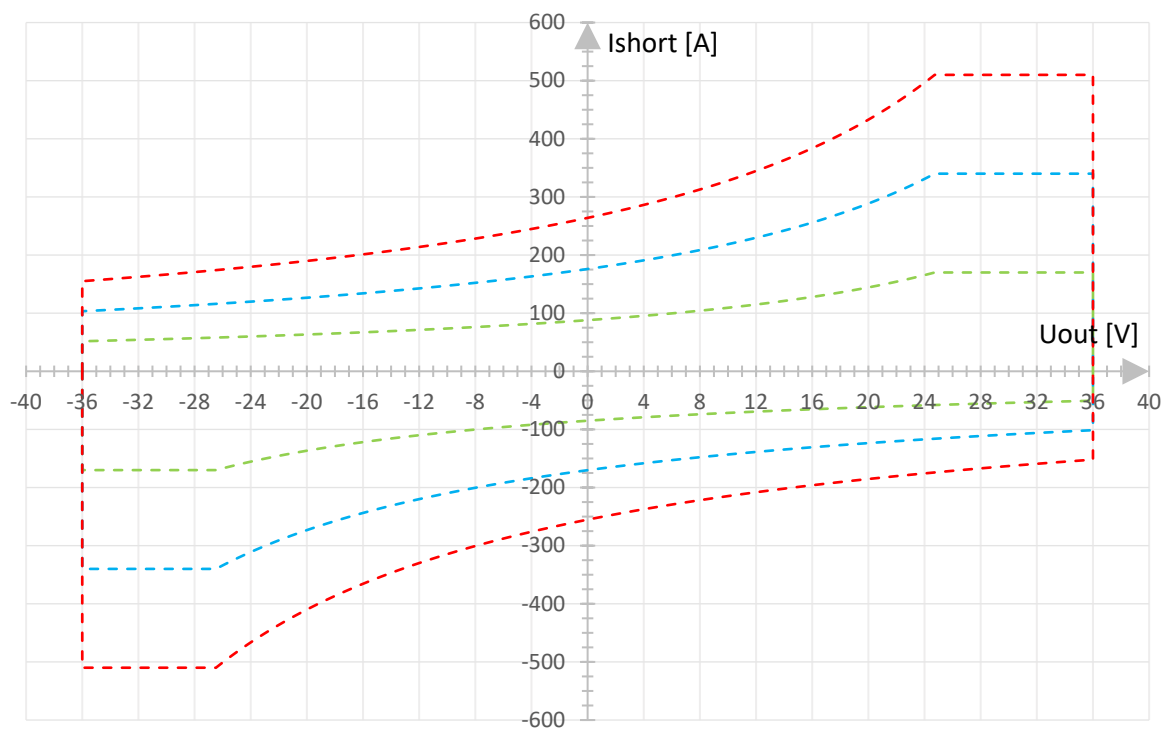

UNSYMMETRIC AMPLIFIER CHARACTERISTIC – OUTPUT CURRENT CAPABILITY
54V Range continuous current I_{cont} : LVA1000 - LVA2500 – LVA5000 – LVA7500

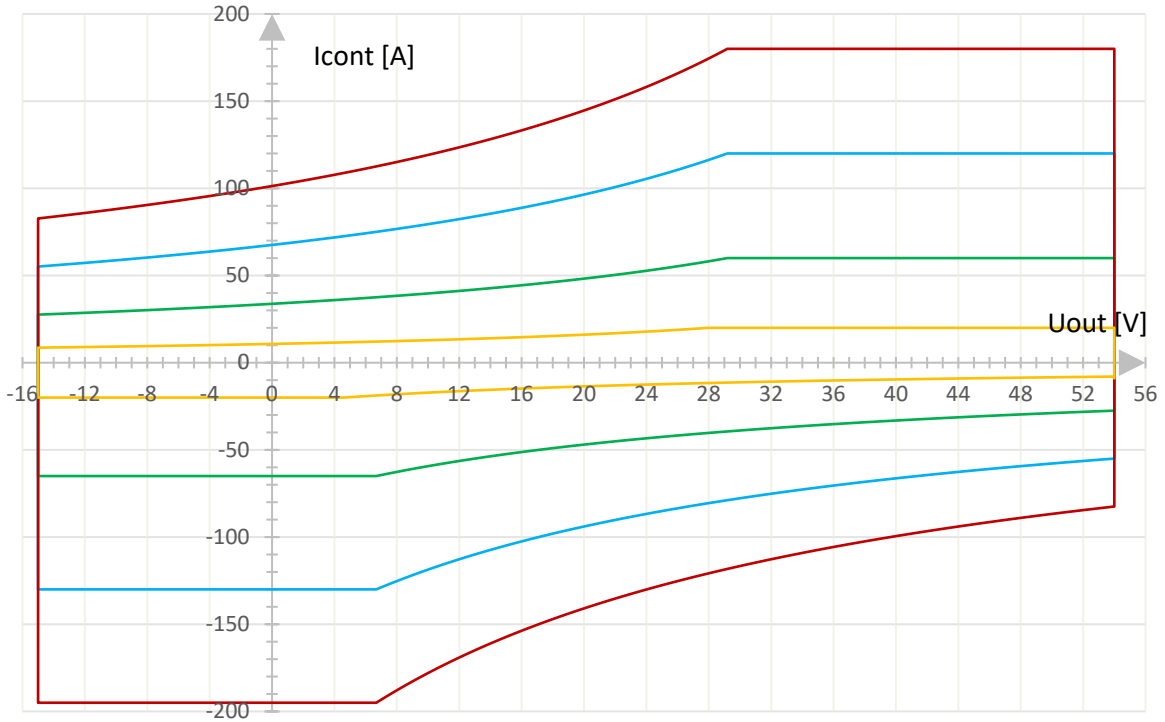

54V Range short-time current I_{short} : LVA1000 - LVA2500 – LVA5000 – LVA7500

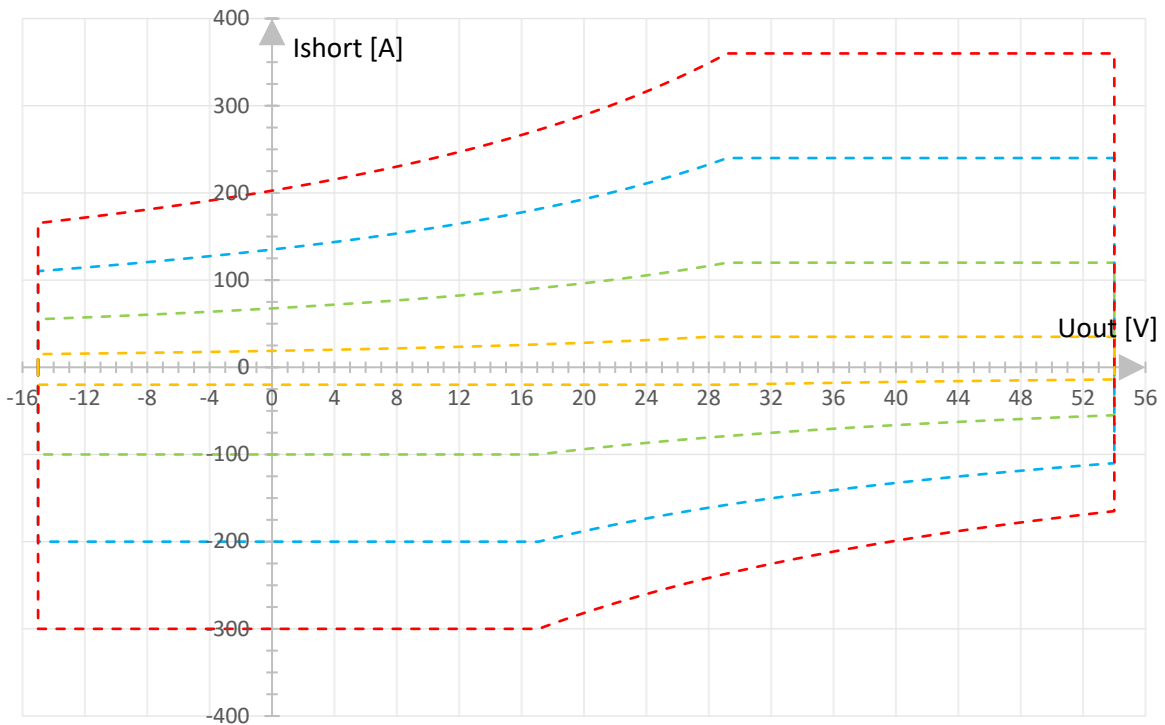

SYMMETRIC AMPLIFIER CHARACTERISTIC – OUTPUT CURRENT CAPABILITY
54V Range continuous current I_{cont} : LVA2500 – LVA5000 – LVA7500

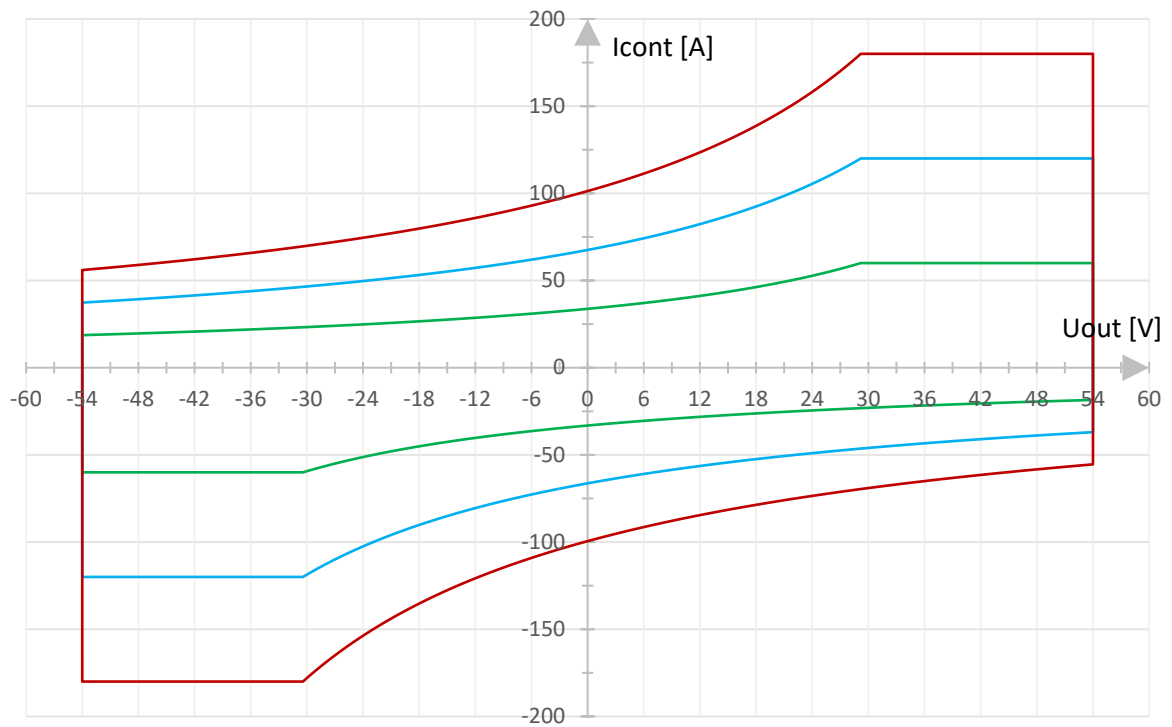

54V Range short-time current I_{short} : LVA2500 – LVA5000 – LVA7500

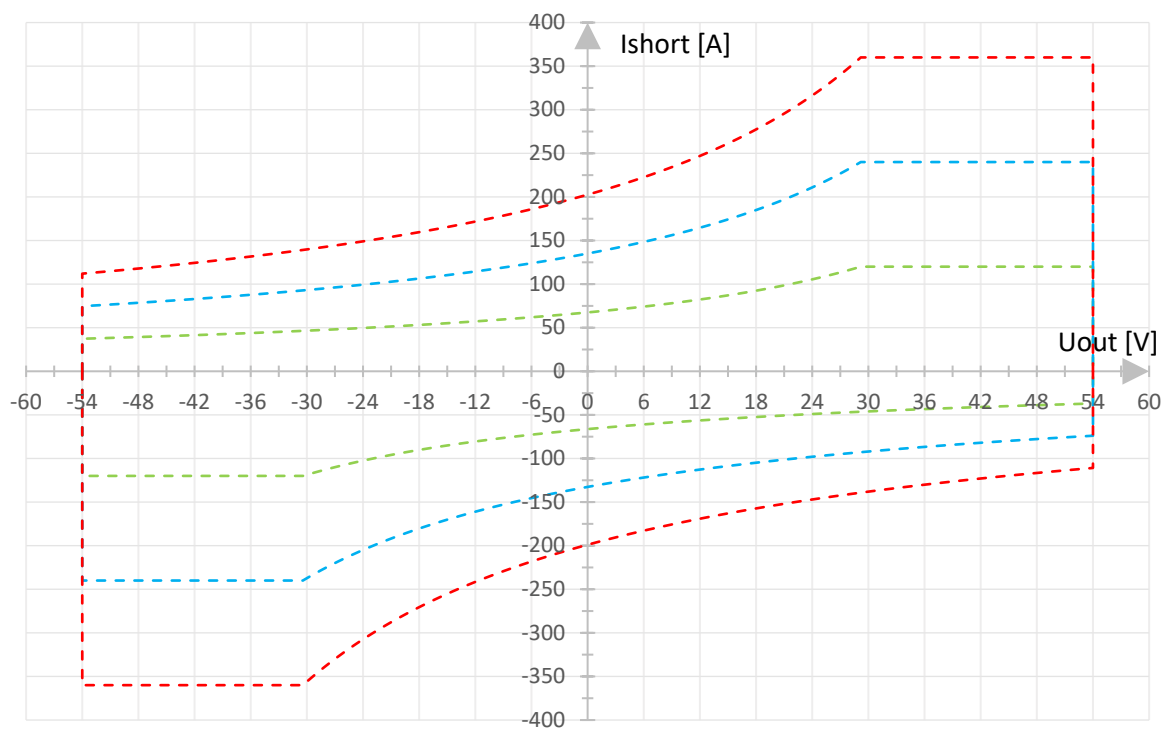

UNSYMMETRIC AMPLIFIER CHARACTERISTIC – OUTPUT CURRENT CAPABILITY
70V Range continuous current I_{cont} : LVA1000 - LVA2500 - LVA5000 - LVA7500

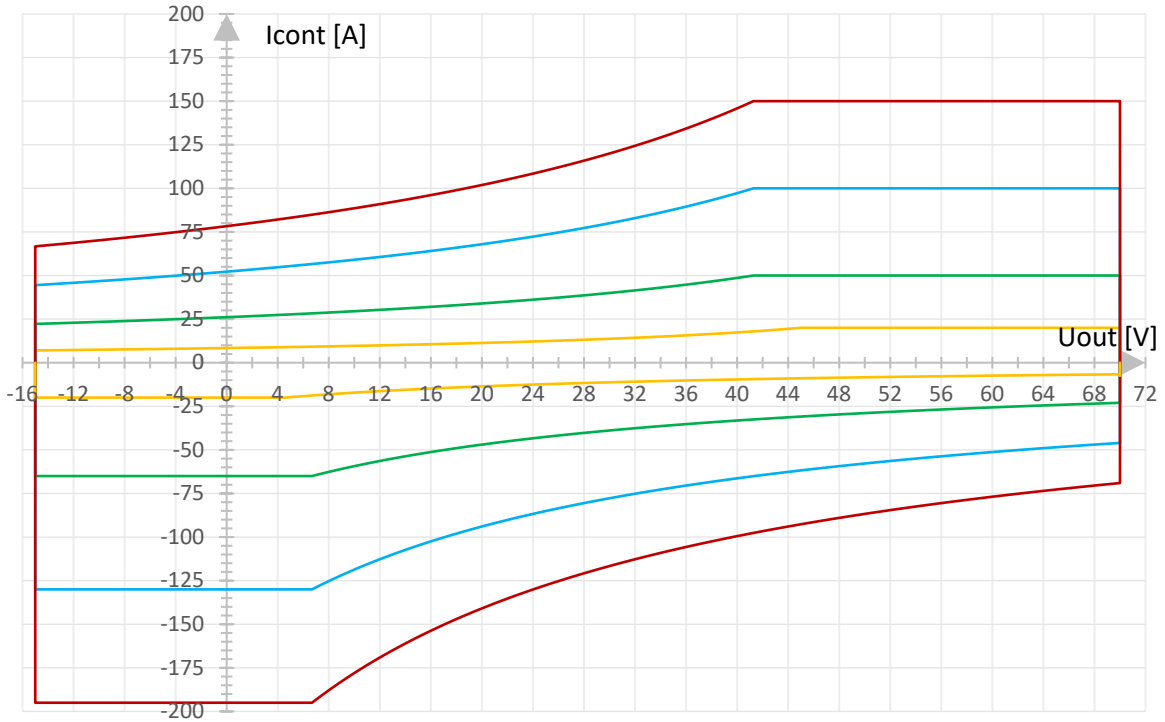

70V Range short-time current I_{short} : LVA1000 - LVA2500 - LVA5000 - LVA7500

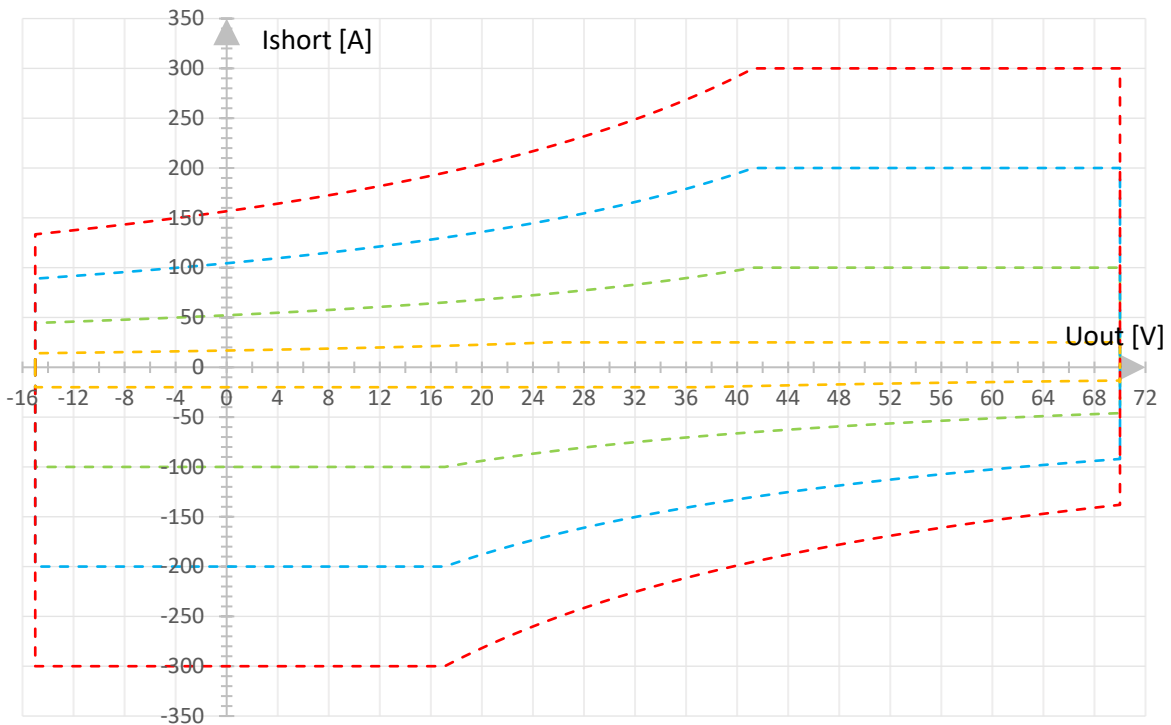

SYMMETRIC AMPLIFIER CHARACTERISTIC – OUTPUT CURRENT CAPABILITY
70V Range continuous current I_{cont} : LVA2500 – LVA5000 – LVA7500

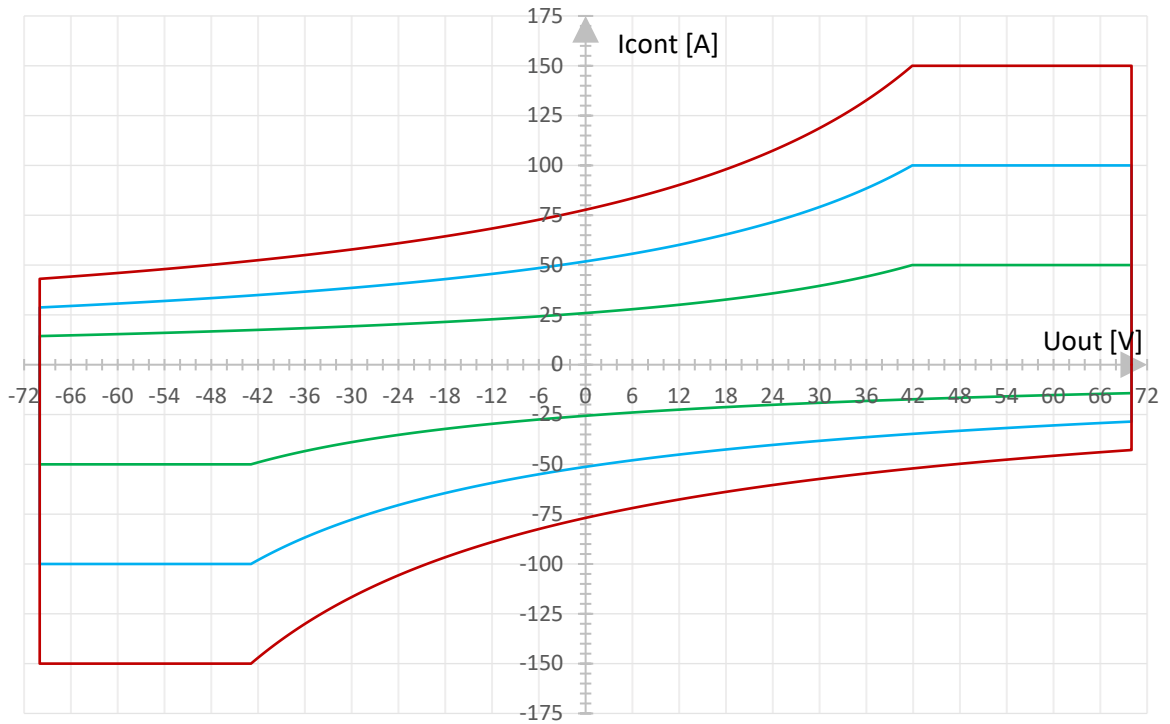

70V Range short-time current I_{short} : LVA2500 – LVA5000 – LVA7500

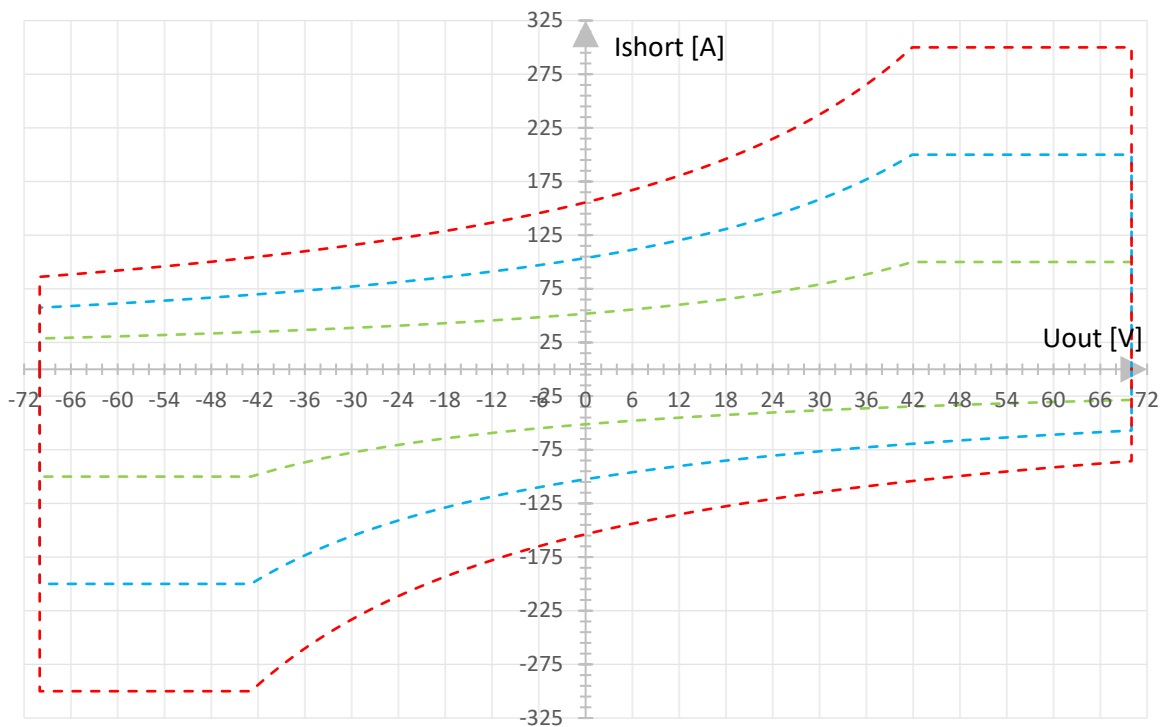

TECHNICAL DATA – TYPE SPECIFIC – UNSYMMETRIC AMPLIFIER

		LVA 1000	LVA 2500
<i>Max. peak current capability:</i> (at 12/24/48/48 V)		100A	300A
<i>Continuous sink current capability:</i>		See characteristics diagram	See characteristics diagram
<i>Continuous power:</i>			
<i>Short-time power:</i> (max 20-30s, duty cycle 1:9)			
<i>Peak power:</i> (max 200ms)			
Nominal Voltages:		<i>Output current capability at maximum output voltage:</i>	
$U_1:$	$0V_{DC} \dots 20V_{DC}$	See characteristics diagram	See characteristics diagram
$U_2:$	$0V_{DC} \dots 36V_{DC}$		
$U_3:$	$0V_{DC} \dots 54V_{DC}$		
$U_4:$	$0V_{DC} \dots 70V_{DC}$		
$U_1 \dots U_4:$	$-15V_{DC} \dots 0V_{DC}$		
Digital instrument:	<i>Voltage range:</i>	Autoranging (20/40/80V Ranges)	
	<i>Current range:</i>	12.5A / 25A / 50A / 100A	37.5A / 75A / 150A / 300A
<i>Accuracy⁽¹⁾:</i>		Voltage (DC): 0.1%	Current (DC): 0.5%
Supply:	<i>Power Supply:</i>	230V ($\pm 10\%$, 50Hz ... 60Hz)	230V/400V ($\pm 10\%$, 50Hz ... 60Hz)
	<i>Protection:</i>	10A	16A
	<i>Connector type:</i>	Schuko	CEE
Housing:	19"-plug-in unit, colour light grey (RAL 7035)		
<i>Dimensions (mm):</i>	Amplifier incl. Power supply (5U) 222x483x700	Amplifier (5U): 222x483x700, Power supply (6U): 267x483x700	
<i>Weight:</i>	approx. 60kg	LVA: approx. 30kg, NT: approx. 90kg	
General:			
<i>Voltage adjustment:</i>		depending on oscillator used	
<i>Load regulation: 0 ... nominal load</i>		max. 0.2%, typ. <0.1%	
<i>Frequency range:</i>		DC ... 300kHz small signal bandwidth	
<i>Noise at output</i>		<5mV _{rms} (<100kHz), <10mV _{rms} (100kHz - 20MHz)	
<i>Slew rate (at load=10Ω):</i>		U: >10V/ μ s	U: >20V/ μ s
Protection circuits:		Overload / Short circuit / Overtemperature	
Input:			
<i>Input voltage: (for max. output)</i>		0 ... V _{ExtMax} (V _{ExtMax} is adjustable between $\pm 2V_p$... $\pm 25V_p$)	
Interface:		Ethernet	
Ambient temperature:		10°C up to +40°C	

Remarks

1) of range value

TECHNICAL DATA – TYPE SPECIFIC – UNSYMMETRIC AMPLIFIER

		LVA 5000	LVA 7500
<i>Max. peak current capability:</i> <i>(at 12/24/48/48 V)</i>		600A	900A
<i>Continuous sink current capability:</i>		See characteristics diagram	See characteristics diagram
<i>Continuous power:</i>			
<i>Short-time power:</i> <i>(max 20-30s, duty cycle 1:9)</i>			
<i>Peak power: (max 200ms)</i>			
Nominal Voltages:		<i>Output current capability at maximum output voltage:</i>	
<i>U₁: 0V_{DC} ... 20V_{DC}</i>		See characteristics diagram	See characteristics diagram
<i>U₂: 0V_{DC} ... 36V_{DC}</i>			
<i>U₃: 0V_{DC} ... 54V_{DC}</i>			
<i>U₄: 0V_{DC} ... 70V_{DC}</i>			
<i>U₁ ... U₄: -15V_{DC} ... 0V_{DC}</i>			
Digital instrument:	<i>Voltage range:</i>	Autoranging (20/40/80V Ranges)	
	<i>Current range:</i>	75A / 150A / 300A / 600A	125A / 250A / 500A / 1000A
<i>Accuracy⁽¹⁾:</i>		Voltage (DC): 0.1%	Current (DC): 1%
Supply:	<i>Power Supply:</i>	230V/400V (±10%, 50Hz ... 60Hz)	
	<i>Protection:</i>	32A	32A
<i>Connector type:</i>		CEE	
Housing:		19"-plug-in unit, colour light grey (RAL 7035)	
<i>Dimensions (mm):</i>		Amplifier (8U): 356x483x700 Power supply(12U): 533x483x700	Amplifier (11U): 489x483x700 Power supply(12U): 533x483x700
<i>Weight:</i>		LVA: approx. 65kg, NT: approx. 200kg	LVA: approx. 75kg, NT: approx. 250kg
General:			
<i>Voltage adjustment:</i>		depending on oscillator used	
<i>Load regulation: 0 ... nominal load</i>		max. 0.2%, typ. <0.1%	
<i>Frequency range:</i>		DC ... 300kHz small signal bandwidth	
<i>Noise at output</i>		<5mV _{rms} (<100kHz), <10mV _{rms} (100kHz - 20MHz)	
<i>Slew rate (at load=10Ω):</i>		U: >20V/μs	
Protection circuits:		Overload / Short circuit / Overtemperature	
Input:			
<i>Input voltage: (for max. output)</i>		±5V _p	
Interface:		Ethernet	
Ambient temperature:		10°C up to +40°C	

Remarks

(1) of range value

INCLUDED FUNCTIONS FOR LVA SERIES

	Adjustable current limitation
	Internal resistance compensation
	Floating output Max. voltage between earth and ground of the output of the amplifier: 300V _{rms}
	External floating input V: 0 ... ±5V _{DC}
	Three additional synthesizer
	Event trigger

ADDITIONAL OPTIONS FOR LVA SERIES

OPT.01	IEEE 488 Interface
OPT.02	RS 232 Interface (instead of IEEE 488 Interface)
OPT.05	Output voltage and current monitor (electrically isolated) Probe ratio free adjustable
NT.11.70S.	Symmetrical voltage range V:0 ... 50V _{rms} (±70V _{DC})
OPT.24.	Programmable internal resistance R:0mΩ ... 200.0mΩ/ Accuracy: ±1% of range
OPT.25.	Constant current mode

ADD-ON DEVICE FOR LVA SERIES

OPD.	Overvoltage protection device
------	-------------------------------



LVA 5000 Front panel